

SMP3200 with EtherCAT — A Zero Hardware Motion/Machine Control Solution



Overview

The SMP3200 with EtherCAT is an innovative 32-axis general motion high-speed controller paired with the popular and proven EtherCAT interface system – a fast, vendor-independent, Ethernet-based realtime open network for servo and I/O communications that works with CANopen over EtherCAT (CoE) servo drives and I/O devices.

With this system, RJ45 Ethernet cables are plugged directly into the Ethernet port on the PC, and servo drives are connected in a simple, single-line daisy-chain – no hardware is required. Up to 32 servo drives (plus additional I/O stations) can be integrated in one network.

This innovative system is ideal for motion control applications in many industries: packaging, materials handling, pick and place, converting, food processing, laser cutting/engraving, plasma cutting, wood-working, semiconductor and more.

The SMP3200 software provides high-end motion control, an industry-standard PLC, and a Windows-based GUI, in a single software package. Running on Windows 2000, Windows XP or Windows XPe, this truly PC-based controller provides an all-software motion and machine control solution.

SMP functions facilitate the setup, configuration, servo tuning and testing of an SMP system, as well as providing real-time monitoring of motion, I/O and PLC status.

The SMP3200 offers great flexibility. Developers can easily embed their motion programming within their customized HMI application, using C/C++ or Visual Basic 6.0.

EtherCAT Features

- Extremely fast – control of up to 32 servo axes with a cycle time as fast as 0.5 ms
- Simple wiring – single-line daisy chain without even a terminator
- Normal, off-the-shelf Ethernet cabling
- Easy to configure, diagnose and maintain
- Less expensive, due to simplified configuration, no plug in cards, no switches/hubs, and standard cabling
- Well proven technology
- Offers redundancy against cable or node failures (with second Ethernet port)
- Servo drives from different manufacturers can be connected in the same network

SMP3200 Components

- The SMP Motion Engine – a real-time soft motion control engine for high-performance, highly-coordinated motion control of up to 32 axes
- The SMP3200 Console – a Windows application that allows users to set up, tune and run an SMP system
- A real-time kernel for Windows
- Motion Development Kit (MDK) Standard Package
- LadderWorks PLC, including:
 - The LadderWorks PLC Engine – a real-time soft PLC engine for industry-standard ladder logic control with axis modules (independent and individual positioning of PLC axes)
 - LadderWorks Console – a graphical PLC ladder diagram editor, monitor, debugger and compiler for Windows
 - PLC utility tools

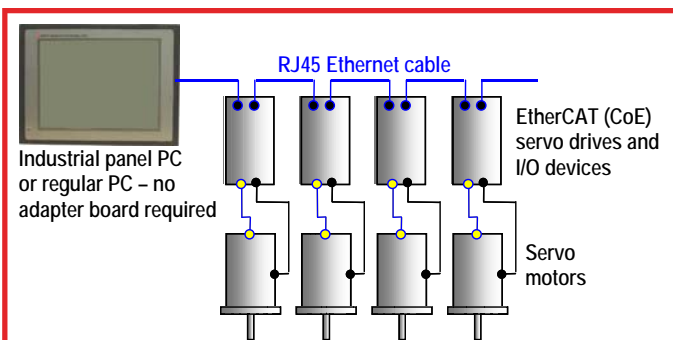

Hardware Connections in the EtherCAT Interface System

SMP3200 Advantages

Powerful and innovative. Easily handles computation-heavy algorithms without additional expensive processors with unique soft motion technology that fully exploits the super-fast, super-precise (double-precision floating point) computation power of ordinary PCs.

Fast. Interpolation rate as fast as 0.5 ms for highly coordinated 32-axis motion. 5 msec standard PLC scan time. Plus, as the speed and power of CPUs increases, so does the speed and power of an SMP product.

Unique technology. A single host CPU performs all real-time servo and motion control tasks, including feedback loops, accelerations/decelerations and PLC, as well as providing the graphical user interface, program interpreting/loading, file management, data processing and network communications, all simultaneously.

Complete coordinated motion/machine control. Soft motion and soft PLC are integrated into a single motion/machine control application for incomparable motion and machine control.

Easy to use software tools. The Motion Development Kit with Visual Basic 6.0 or C/C++ APIs makes it easy to design and program customized control/GUI applications.

Extendable. Windows-based SMP allows customers to take advantage of sophisticated or simple user interfaces; connectivity to enterprise networks; off-the-shelf PC technology; integration with third-party Windows-based software, such as vision systems or statistical process control software; and remote diagnostic service.

Reduced hardware. Emphasizing software components and taking advantage of a computer's CPU considerably reduces hardware requirements and complex interface wiring and eliminates high-priced proprietary encoder- or servo-specific interface modules, breakout boxes, and analog and encoder cables from the PC.



SMP3200 Console Application

SMP3200 Motion Control Features

- Up to 32 axes of coordinated motion control with an interpolation cycle as fast as 0.5 ms
- PLC axes for independent, individual positioning
- Linear, circular, helical and exponential interpolation
- Backlash compensation and leadscrew pitch error compensation
- Smoothing: acceleration and deceleration can be programmed for linear, bell-shaped and exponential filters
- Velocity feedforward to improve motion performance
- Dual-axis synchronous control for master-slave operation
- Corner deceleration control for sharper corners while maintaining high feedrates away from corners
- 1000 cycle three-dimensional dynamic look-ahead contour control (3D-DLACC) with pre-interpolation acceleration for high-speed, high-precision machining (one second look-ahead for 1 ms position feedback rate)

SMP Motion Development Kit (MDK)

The SMP MDK (Standard Package included) has made it easy for users to create or customize their own SMP application in C/C++, Visual Studio 6.0 or .NET 2.0 for Windows 2000/XP/XPe. SMP Motion and Logic APIs with plenty of sample source code in the MDK allow customers to easily program their own GUI or text-based SMP application. These extensive APIs are provided for complete and full access to all real-time processes and resources.

The Visual Basic source code of the SMP Console, an intensive motion application for Windows, is available with the MDK.

Also available is the SMP Simulator that allows users to “play” with SMP motion products without having hardware or motors connected to the PC. The SMP Simulator can be used not only for SMP application development, but also for training end users of the developed SMP applications.

EtherCAT Communications

EtherCAT (Ethernet Control Automation Technology) is an industrial Ethernet fieldbus network that is real-time down to the I/O level – no delays in gateways, no underlying sub-systems.

This interface system is based on 100 Mbps Ethernet.

Consult the *Soft Servo SMP Series General Motion Control Product Parts List* or your Soft Servo Systems sales representative regarding standard and optional features for this product.



Soft Servo Systems, Inc.
Control the Future

39 Whitcomb Street, Waltham, MA 02453, USA Tel: 1.781.891.9555 Fax: 1.781.891.3853 www.softservo.com

Send inquiries to: info_usa@softservo.com

Revised June 12, 2009